

# Quick-Fit® EMC Cable Glands, Brass, Nickel plated

Rapid EMC connection of the cable shield through contact spring inside gland body and the electric potential of the installation.  
 Built-in twisting protection, wide sealing and clamping range

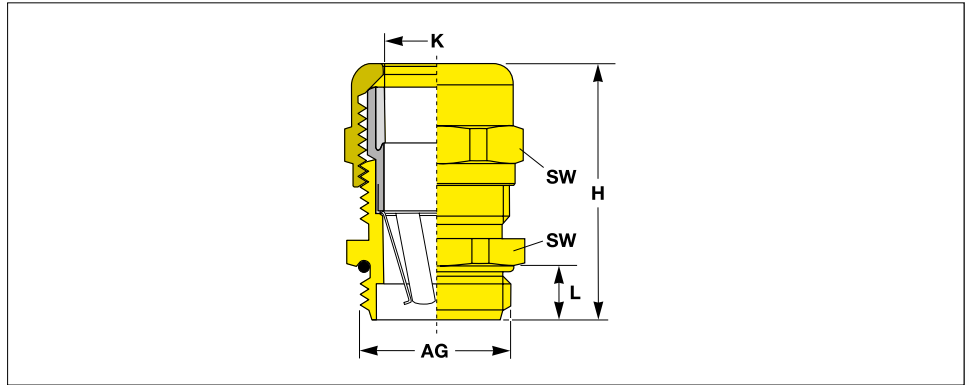

Cable glands play an important part in safeguarding EMC requirements where cables and leads enter into a shielding system. They must ensure a durable permanent connection with very small Ohm's and inductive resistance between the cable shield and the housing potential. Our QUICK-FIT EMC cable glands fulfil these requirements in an outstanding way.

The assembly of the type EPN 705 succeeds simply and fast:

1. Partially expose the braid by removing the outer sheath of the cable of approximately 10 mm.
2. Insert the cable through the domed nut and the gland body until the contact spring is pressed against the braided screen.
3. Firmly screw on domed nut.
4. Due to this principle it is possible to conduct the braided screen of the EMC cable through the entire gland body up to the clamping are of the inner wires.

An additional improvement of the equipotential bonding and the vibration protection can be improved further by using our EPN 715 hexagon nut with cutting edges obtained.

See page 148

All dimensions in mm

Thread size	Clamping range	Length of thread	Depth	Spanner size	Reference-No.
AG	K	L	H	SW	
M 16 × 1.5	5.0 – 9.0	5.0	30.0	17	EPN 705 / M 16 × 1.5
M 20 × 1.5	9.0 – 13.0	6.0	33.1	22	EPN 705 / M 20 × 1.5
M 25 × 1.5	11.0 – 16.0	7.0	35.0	27	EPN 705 / M 25 × 1.5
M 32 × 1.5	14.0 – 21.0	8.0	39.0	34	EPN 705 / M 32 × 1.5
M 40 × 1.5	19.0 – 27.0	8.0	41.7	43	EPN 705 / M 40 × 1.5
M 50 × 1.5	24.0 – 35.0	9.0	50.1	55	EPN 705 / M 50 × 1.5
M 63 × 1.5	32.0 – 42.0	10.0	52.5	65	EPN 705 / M 63 × 1.5

Should your requirements not be shown please ask for a separate quotation. SEALWELL products and specifications are subject to improvement and change without notice.

**Material :**  
Brass, nickel plated

**Blade insert :**  
Polyamide PA6 V-2

**Sealing ring :**  
Polychloroprene-Nitrile rubber CR/NBR

**O-Ring :**  
Nitrile rubber NBR

**Protection grade :**  
IP68

Rapid EMC connection of the cable shield through contact spring inside gland body and the electric potential of the installation. Built-in twisting protection, wide sealing and clamping range.

# Quick-Fit® EMC Cable Glands, Brass, Nickel plated

Rapid EMC connection of the cable shield through contact spring inside gland body and the electric potential of the installation.

Built-in twisting protection, wide sealing and clamping range

## TRIPLE ADVANTAGE of QUICK-FIT™

**QUALITY.** This EMC / EMI cable gland is designed to ground cable braids directly to the wall with optimum contact to the periphery of the glandbase.

**AVAILABILITY.** With over 400 million moulded components shipped from our Oststeinbek / Hamburg logistics center we provide the fastest on time delivery service to all markets and industries.

**PHILOSOPHY.** The highest degree of Protec Quick-Fit functionality and safety at the best price in the market.



**Material :**

Brass,  
nickel plated

**Individual Productions :**

On request we develop and produce individually tailored solutions next to the standard items of this range: additional dimensions, different materials and new colours

We would be pleased to advise you.

 sealwell