

# Quick-Fit® Hexagonal Locknuts with flange

For secure tightening of cable glands and accessories

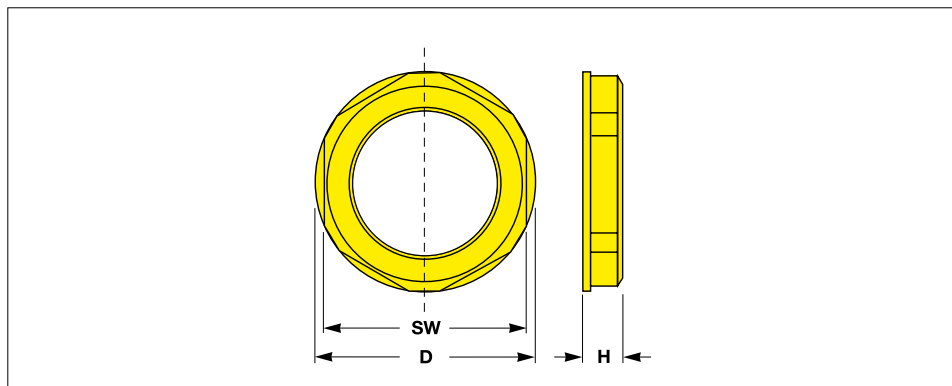

**Material :**

PA 6,  
impact resistant nylon

**Standard Colours :**

light grey RAL 7035  
dark grey RAL 7001  
black RAL 9005

**optional :**

white RAL 9010  
red RAL 3000

Optional colours on request.

For secure tightening of cable glands and accessories



All dimensions in mm

Thread Size	Depth	Spanner size	Ø	Material	Reference-No.
	H	SW	D		
M 16 × 1.5	7.0	19	22.5	PA	EPN 350 / M 16 × 1.5
M 20 × 1.5	8.0	24	28.0	PA	EPN 350 / M 20 × 1.5
M 25 × 1.5	9.0	27	31.5	PA	EPN 350 / M 25 × 1.5

Should your requirements not be shown please ask for a separate quotation.  
SEALWELL products and specifications are subject to improvement and change without notice.

# Quick-Fit® Hexagonal Locknuts with flange

For secure tightening of cable glands and accessories

## TRIPLE ADVANTAGE of QUICK-FIT®

**QUALITY.** Hexagon shaped with round sealing flange.  
To fit a variety of thread sizes, and to execute a range of applications.  
Nylon nuts are durable, non-conductive and resistant to corrosion.

**AVAILABILITY.** With over 400 million moulded components shipped from our Oststeinbek / Hamburg logistics center we provide the fastest on time delivery service to all markets and industries.

**PHILOSOPHY.** The highest degree of Protec Quick-Fit functionality and safety at the best price in the market.



**Material :**  
PA 6,  
impact resistant nylon

**Standard Colours :**  
light grey      RAL 7035  
dark grey      RAL 7001  
black            RAL 9005

**optional :**  
white            RAL 9010  
red               RAL 3000

Optional colours on request.

**Individual Productions :**  
On request we develop and produce individually tailored solutions next to the standard items of this range: additional dimensions, different materials and new colours

We would be pleased to advise you.

 sealwell