

Bolt and Nut Anti-Corrosion Snap Caps

EP 810 bolt and Nut corrosion Caps can also be used on existing bolt and nut assemblies showing signs of corrosion!
With anti-vibration locking lip

EX STOCK
400m
Parts
DELIVERY SERVICE



Introduction

Corrosion happens when oxygen and moisture mix, creating what is commonly known as rust. When this moisture and the oxygen are sealed out, an object is protected from such atmospheric corrosion and thus its life is extended.

EP 810 Bolt and Nut Corrosion Caps are designed and manufactured to prevent the corrosion of bolt studs and hexagon nuts.

Economical, reusable and easy to install. No tools required.

EP 810 Bolt and Nut Corrosion Caps can also be used on existing bolt and nut assemblies showing signs of corrosion! Using EP 810 Bolt and Nut Corrosion Caps in conjunction with corrosion resistant grease will inhibit further corrosion. More details available on request.

Installation

EP 810 Bolt and Nuts Corrosion Caps offer maximum rust protection for both bolt studs and hexagon nuts. The vertical locking lip secures itself under the hexagon nut creating anti-vibration protection and the perfect anti-corrosion seal over the bolt stud and hexagon nut connection.

EP 810 Bolt and Nut Corrosion Caps are supplied with either standard or extended length barrels. The extended barrel is used in conjunction with tensioning devices. Tensioners require a thread height of approximately two times the thread length for twelve exposed threads. The standard length barrel is used where tensioners are not required and it allows for up to six exposed threads.

Material :
LD-PE,
low density polyethylene

Standard Colour :
black

Durable snap-on installation
With anti-vibration locking lip
175 Designs and Sizes

Designed to fit bolts, bolt ends, nuts and screws and developed to provide almost total protection against corrosion, humidity and operational damage.

 sealwell

EP 810 Type -1- For standard bolts and hexagon nuts used without washers. Standard and extended barrels available.

EP 810 Type -2- For standard bolts and hexagon nuts used with washers. Extended barrels available only.

EP 810 Type -3- Adjustable telescopic cap assembled in two parts to fit different and non-standard bolt configurations. Custom specific design.

Bolt and Nut Anti-Corrosion Snap Caps

EP 810 bolt and Nut corrosion Caps can also be used on existing bolt and nut assemblies showing signs of corrosion!
With anti-vibration locking lip



CAPTOP®

Material :
LD-PE,
low density polyethylene

Standard Colour :
black

Individual Productions :
On request we develop and produce individually tailored solutions next to the standard items of this range: additional dimensions, different materials and new colours

We would be pleased to advise you.

 sealwell

Bolt and Nut Anti-Corrosion Snap Caps

For bolted joints **without** washers

With anti-vibration locking lip

Width across flats range from SW 10 to SW 130

prompt

MADE-TO-ORDER
VOLUME

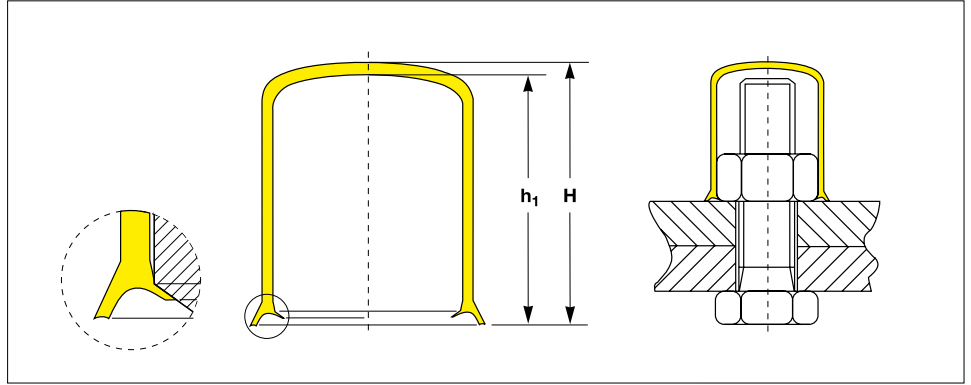

All dimensions in mm

Widths across Flats	Type	Dimensions		Thread			DIN 11 • UNC American National Standards	EP 810 Type -1-
		Height Inside	Height outside	DIN 439 Typ B (DIN ISO 4035, 8675) DIN 55 (DIN ISO 4034) DIN 934 (DIN ISO 4032,8673, 8674) DIN 936 (DIN ISO 4035,8675) DIN 972 (DIN ISO 4034)				Reference-No.
		h ₁	H	Metric Thread				
SW 10	-1-	16.1	17.2	M 6				EP 810 / SW 10 – M 6 -1- G 16
SW 10	-1-	33.6	34.7	M 6				EP 810 / SW 10 – M 6 -1- G 34
SW 13	-1-	18.0	19.1	M 8			.1/ 4"	EP 810 / SW 13 – M 8 -1- G 18
SW 13	-1-	27.0	28.6	M 8			.1/ 4"	EP 810 / SW 13 – M 8 -1- G 27
SW 17	-1-	31.2	33.2	M 10		M 10 × 1	.3/ 8"	EP 810 / SW 17 – M 10 -1- G 29
SW 17	-1-	44.2	46.0	M 10		M 10 × 1	.3/ 8"	EP 810 / SW 17 – M 10 -1- G 45
SW 19	-1-	31.1	32.9	M 12		M 12 × 1.5	.7/16"	EP 810 / SW 19 – M 12 -1- G 29
SW 19	-1-	50.0	52.0	M 12		M 12 × 1.5	.7/16"	EP 810 / SW 19 – M 12 -1- G 50
SW 24	-1-	34.2	36.3	M 16		M 16 × 1.5	.9/16"	EP 810 / SW 24 – M 16 -1- G 31
SW 24	-1-	50.5	52.0	M 16		M 16 × 1.5	.9/16"	EP 810 / SW 24 – M 16 -1- G 51
SW 30	-1-	33.5	36.0	M 20	M 20 × 2	M 20 × 1.5		EP 810 / SW 30 – M 20 -1- G 34
SW 30	-1-	116.0	118.0	M 20	M 20 × 2	M 20 × 1.5		EP 810 / SW 30 – M 20 -1- G 120
SW 36	-1-	72.6	75.0	M 24	M 24 × 2	M 24 × 1.5	.7/8"	EP 810 / SW 36 – M 24 -1- G 73
SW 36	-1-	42.0	44.3	M 24	M 24 × 2	M 24 × 1.5	.7/8"	EP 810 / SW 36 – M 24 -1- G 43
SW 41	-1-	76.2	78.4	M 27	M 27 × 2	M 27 × 1.5	1."	EP 810 / SW 41 – M 27 -1- G 76
SW 41	-1-	51.5	54.0	M 27	M 27 × 2	M 27 × 1.5	1."	EP 810 / SW 41 – M 27 -1- G 46
SW 46	-1-	148.0	151.0	M 30	M 30 × 2	M 30 × 1.5	1.1/8"	EP 810 / SW 46 – M 30 -1- G 144
SW 46	-1-	50.7	53.0	M 30	M 30 × 2	M 30 × 1.5	1.1/8"	EP 810 / SW 46 – M 30 -1- G 49
SW 50	-1-	85.0	87.0	M 33	M 33 × 2	M 33 × 1.5	1.1/4"	EP 810 / SW 50 – M 33 -1- G 81
SW 50	-1-	56.0	58.0	M 33	M 33 × 2	M 33 × 1.5	1.1/4"	EP 810 / SW 50 – M 33 -1- G 51
SW 55	-1-	164.5	167.5	M 36	M 36 × 3	M 36 × 1.5	1.3/8"	EP 810 / SW 55 – M 36 -1- G 155
SW 55	-1-	56.8	60.0	M 36	M 36 × 3	M 36 × 1.5	1.3/8"	EP 810 / SW 55 – M 36 -1- G 55
SW 60	-1-	58.1	60.5	M 39	M 39 × 3	M 39 × 1.5	1.1/2"	EP 810 / SW 60 – M 39 -1- G 57
SW 60	-1-	109.4	113.0	M 39	M 39 × 3	M 39 × 1.5	1.1/2"	EP 810 / SW 60 – M 39 -1- G 107
SW 65	-1-	123.0	126.0	M 42	M 42 × 3	M 42 × 1.5	1.5/8"	EP 810 / SW 65 – M 42 -1- G 123
SW 65	-1-	62.7	64.6	M 42	M 42 × 3	M 42 × 1.5	1.5/8"	EP 810 / SW 65 – M 42 -1- G 61

Type -1-

Standard Version
for bolted joints
without washers

Material :
LD-PE,
low density polyethylene

Standard Colour :
black

- Resistant against chemicals
- Temperature range,
resistant from -25°C up to +70°C

Available in standard and extended barrels.

 sealwell

Should your requirements not be shown please ask for a separate quotation.

SEALWELL products and specifications are subject to improvement and change without notice.

Bolt and Nut Anti-Corrosion Snap Caps

For bolted joints **without washers**

With anti-vibration locking lip

Width across flats range from SW 10 to SW 130



CAPTOP®

All dimensions in mm

Widths across Flats	Type	Dimensions		Thread		DIN 11 · UNC American National Standards	EP 810 Type -1-	
		Height Inside	Height outside	DIN 439 Typ B (DIN ISO 4035, 8675) DIN 55 (DIN ISO 4034) DIN 934 (DIN ISO 4032,8673, 8674) DIN 936 (DIN ISO 4035,8675) DIN 972 (DIN ISO 4034)			Reference-No.	
		h ₁	H	Metric Thread				
SW 70	-1-	62.0	65.0	M 45		1.3/4"	EP 810 / SW 70 – M 45 -1- G 63	
SW 70	-1-	113.5	118.0	M 45		1.3/4"	EP 810 / SW 70 – M 45 -1- G 113	
SW 75	-1-	63.0	70.0	M 48		1.7/8"	EP 810 / SW 75 – M 48 -1- G 66	
SW 75	-1-	95.0	97.0	M 48		1.7/8"	EP 810 / SW 75 – M 48 -1- G 96	
SW 80	-1-	71.0	77.0	M 52		2."	EP 810 / SW 80 – M 52 -1- G 70	
SW 80	-1-	130.0	133.0	M 52		2."	EP 810 / SW 80 – M 52 -1- G 130	
SW 85	-1-	133.6	138.0	M 56			EP 810 / SW 85 – M 56 -1- G 134	
SW 85	-1-	74.0	76.5	M 56			EP 810 / SW 85 – M 56 -1- G 74	
SW 90	-1-	85.5	88.0	M 60		2.1/4"	EP 810 / SW 90 – M 60 -1- G 78	
SW 90	-1-	140.0	145.0	M 60		2.1/4"	EP 810 / SW 90 – M 60 -1- G 140	
SW 95	-1-	143.0	148.0	M 64			EP 810 / SW 95 – M 64 -1- G 143	
SW 95	-1-	88.0	91.5	M 64			EP 810 / SW 95 – M 64 -1- G 86	
SW 100	-1-	89.8	94.0	M 68			EP 810 / SW 100 – M 68 -1- G 90	
SW 100	-1-	153.5	157.5	M 68			EP 810 / SW 100 – M 68 -1- G 150	
SW 105	-1-	149.1	154.0	M 72			EP 810 / SW 105 – M 72 -1- G 150	
SW 105	-1-	92.7	98.0	M 72			EP 810 / SW 105 – M 72 -1- G 90	
SW 107	-1-	95.0	102.5	M 76		2. 3/4"	EP 810 / SW 107 – M 76 -1- G 95	
SW 115	-1-	180.2	187.0	M 80			EP 810 / SW 115 – M 80 -1- G 180	
SW 115	-1-	97.0	106.0	M 80			EP 810 / SW 115 – M 80 -1- G 97	
SW 117	-1-	100.0	108.0	M 85		3."	EP 810 / SW 117 – M 85 -1- G 100	
SW 130	-1-	108.5	115.0	M 90		3.1/4"	EP 810 / SW 130 – M 90 -1- G 100	

Should your requirements not be shown please ask for a separate quotation.

SEALWELL products and specifications are subject to improvement and change without notice.

Type -1-
Standard Version
for bolted joints
without washers

Material :
LD-PE,
low density polyethylene

Standard Colour :
black

Individual Productions :
On request we develop and produce individually tailored solutions next to the standard items of this range: additional dimensions, different materials and new colours

We would be pleased to advise you.

 sealwell

Bolt and Nut Anti-Corrosion Snap Caps

For bolted joints with washers
 With anti-vibration locking lip
 Width across Flats range from SW 10 to SW 105

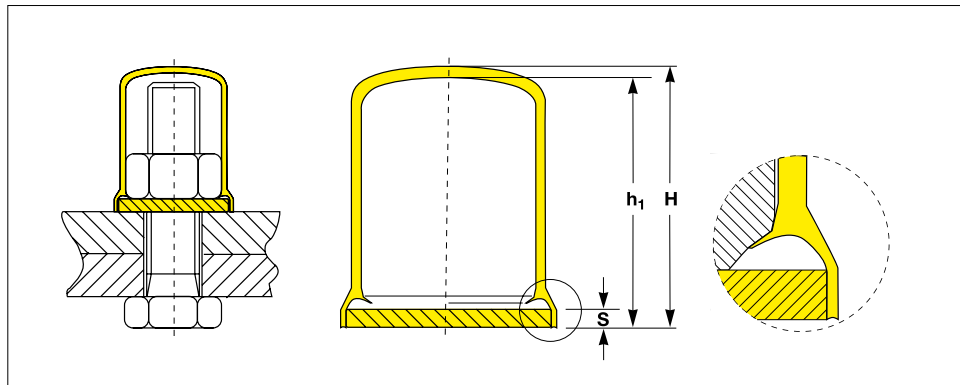

All dimensions in mm

Type -2-
 Extended Version
 for bolted joints
 with washers

Widths across Flats	Type	Dimensions of caps			Thread			DIN 11 · UNC American National Standards	EP 810 Type -2-
		Height inside h ₁	Height outside H	Thickness Washer S	Metric Thread				Reference-No.
					DIN 439 Typ B (DIN ISO 4035, 8675) DIN 55 (DIN ISO 4034) DIN 934 (DIN ISO 4032,8673, 8674) DIN 936 (DIN ISO 4035,8675) DIN 972 (DIN ISO 4034)				
SW 10	-2-	17.8	19.1	1.6	M 6				EP 810 / SW 10 - M 6 -2- G 18
SW 13	-2-	28.6	30.2	1.6	M 8			.1/4"	EP 810 / SW 13 - M 8 -2- G 29
SW 17	-2-	47.2	49.0	2.0	M 10		M 10 × 1	.3/8"	EP 810 / SW 17 - M 10 -2- G 47
SW 19	-2-	41.1	43.1	2.5	M 12		M 12 × 1.5	.7/16"	EP 810 / SW 19 - M 12 -2- G 40
SW 24	-2-	69.0	70.8	3.0	M 16		M 16 × 1.5	.9/16"	EP 810 / SW 24 - M 16 -2- G 69
SW 30	-2-	82.0	84.0	3.0	M 20	M 20 × 2	M 20 × 1.5		EP 810 / SW 30 - M 20 -2- G 82
SW 36	-2-	121.4	123.8	4.7	M 24	M 24 × 2	M 24 × 1.5	.7/8"	EP 810 / SW 36 - M 24 -2- G 120
SW 41	-2-	88.0	92.0	4.0	M 27	M 27 × 2	M 27 × 1.5	1."	EP 810 / SW 41 - M 27 -2- G 80
SW 46	-2-	81.7	84.0	4.0	M 30	M 30 × 2	M 30 × 1.5	1.1/8"	EP 810 / SW 46 - M 30 -2- G 83
SW 50	-2-	87.0	90.0	5.0	M 33	M 33 × 2	M 33 × 1.5	1.1/4"	EP 810 / SW 50 - M 33 -2- G 86
SW 55	-2-	91.0	93.5	5.3	M 36	M 36 × 3	M 36 × 1.5	1.3/8"	EP 810 / SW 55 - M 36 -2- G 90
SW 55	-2-	163.0	173.0	5.0	M 36	M 36 × 4	M 36 × 1.5	1.3/8"	EP 810 / SW 55 - M 36 -2- G 160
SW 60	-2-	105.0	107.0	6.0	M 39	M 39 × 3	M 39 × 1.5	1.1/2"	EP 810 / SW 60 - M 39 -2- G 93
SW 65	-2-	95.2	98.0	7.7	M 42	M 42 × 3	M 42 × 1.5	1.5/8"	EP 810 / SW 65 - M 42 -2- G 98
SW 70	-2-	100.0	102.0	7.0	M 45			1.3/4"	EP 810 / SW 70 - M 45 -2- G 100
SW 75	-2-	108.0	110.0	10.5	M 48			1.7/8"	EP 810 / SW 75 - M 48 -2- G 103
SW 80	-2-	138.0	141.0	8.0	M 52			2."	EP 810 / SW 80 - M 52 -2- G 139
SW 85	-2-	83.0	86.0	9.0	M 56				EP 810 / SW 85 - M 56 -2- G 83
SW 90	-2-	84.3	86.3	10.1	M 60			2.1/4"	EP 810 / SW 90 - M 60 -2- G 83
SW 95	-2-	143.0	145.0	11.8	M 64				EP 810 / SW 95 - M 64 -2- G 140
SW 100	-2-	150.0	158.0	9.0	M 68			2.1/2"	EP 810 / SW 100 - M 68 -2- G 150
SW 105	-2-	162.5	167.0	9.0	M 72				EP 810 / SW 105 - M 72 -2- G 160

Material :
 LD-PE,
 low density polyethylene

Standard Colour :
 black

- Resistant against chemicals
- Temperature range,
 resistant from -25°C up to +70°C

Available in standard and extended barrels.

Should your requirements not be shown please ask for a separate quotation.
 SEALWELL products and specifications are subject to improvement and change without notice.

Bolt and Nut Adjustable Telescopic Corrosion Cap

For bolted joints without washers

With anti-vibration locking lip

Adjustable for extremely large bolt length

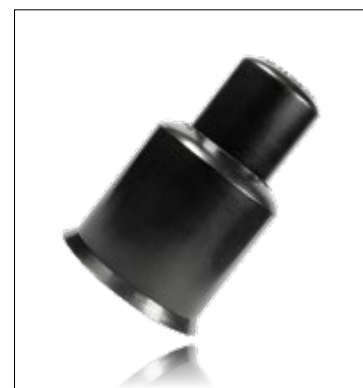
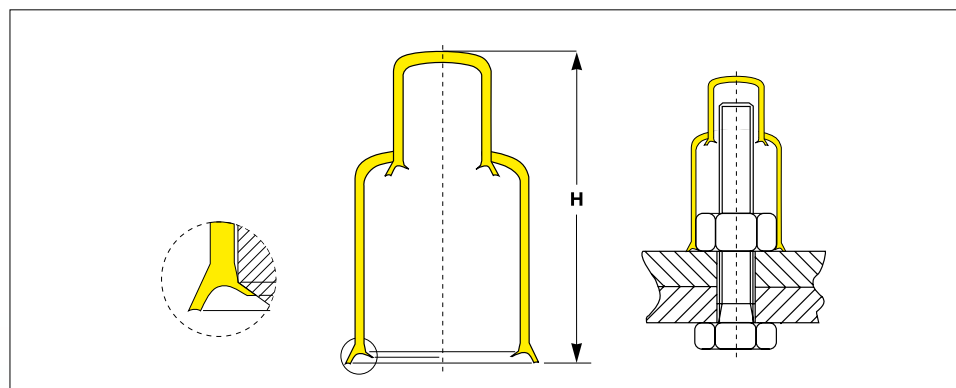

CAPTOP®

All dimensions in mm

		Base Cap					Top Cap		Telescopic Corrosion Cap		
Widths across Flats	Type	Dimensions of caps		Thread			Reference No. EP 810/	Max. Height inside H	EP 810 Type -3.1-		
		Height Inside h ₁	Height outside H	Metric Thread	DIN 11 · UNC American National Standards	Reference No. EP 810/			Reference-No.		
SW 24	-3.1-	33.5	36.0	M 16	.9/16"	SW 24-1-G 31	SW 17-1-G 29	57.0	EP 810 / SW 24-3.1-G 57		
SW 24	-3.1-	33.5	36.0	M 16	.9/16"	SW 24-1-G 31	SW 17-1-G 45	73.0	EP 810 / SW 24-3.1-G 73		
SW 24	-3.1-	49.2	52.0	M 16	.9/16"	SW 24-1-G 51	SW 17-1-G 29	73.0	EP 810 / SW 24-3.1-G 73		
SW 24	-3.1-	49.2	52.0	M 16	.9/16"	SW 24-1-G 51	SW 17-1-G 45	89.0	EP 810 / SW 24-3.1-G 89		
SW 30	-3.1-	33.5	36.0	M 20		SW 30-1-G 34	SW 19-1-G 29	57.0	EP 810 / SW 30-3.1-G 57		
SW 30	-3.1-	33.5	36.0	M 20		SW 30-1-G 34	SW 19-1-G 50	78.0	EP 810 / SW 30-3.1-G 78		
SW 30	-3.1-	116.0	119.0	M 20		SW 30-1-G 120	SW 19-1-G 29	140.0	EP 810 / SW 30-3.1-G 140		
SW 30	-3.1-	116.0	119.0	M 20		SW 30-1-G 120	SW 19-1-G 50	161.0	EP 810 / SW 30-3.1-G 161		
SW 36	-3.1-	41.8	45.0	M 24	.7/8"	SW 36-1-G 43	SW 24-1-G 31	70.0	EP 810 / SW 36-3.1-G 70		
SW 36	-3.1-	41.8	45.0	M 24	.7/8"	SW 36-1-G 43	SW 24-2-G 69	99.0	EP 810 / SW 36-3.1-G 99		
SW 36	-3.1-	71.1	75.0	M 24	.7/8"	SW 36-1-G 73	SW 24-1-G 69	99.0	EP 810 / SW 36-3.1-G 99		
SW 36	-3.1-	132.0	134.0	M 24	.7/8"	SW 36-1-G 73	SW 24-2-G 69	132.0	EP 810 / SW 36-3.1-G 128		
SW 41	-3.1-	50.1	54.0	M 27	1."	SW 41-1-G 46	SW 30-1-G 34	78.0	EP 810 / SW 41-3.1-G 78		
SW 41	-3.1-	50.1	54.0	M 27	1."	SW 41-1-G 46	SW 30-1-G 120	161.0	EP 810 / SW 41-3.1-G 161		
SW 41	-3.1-	104.5	106.5	M 27	1."	SW 41-1-G 76	SW 30-1-G 34	102.0	EP 810 / SW 41-3.1-G 102		
SW 41	-3.1-	73.8	78.0	M 27	1."	SW 41-1-G 76	SW 30-1-G 120	184.0	EP 810 / SW 41-3.1-G 184		
SW 46	-3.1-	50.7	53.0	M 30	1.1/8"	SW 46-1-G 49	SW 30-1-G 34	79.0	EP 810 / SW 46-3.1-G 79		
SW 46	-3.1-	50.7	53.0	M 30	1.1/8"	SW 46-1-G 49	SW 30-1-G 120	161.0	EP 810 / SW 46-3.1-G 161		
SW 46	-3.1-	145.5	150.0	M 30	1.1/8"	SW 46-1-G 144	SW 30-1-G 34	174.0	EP 810 / SW 46-3.1-G 174		
SW 46	-3.1-	145.5	150.0	M 30	1.1/8"	SW 46-1-G 144	SW 30-1-G 120	256.0	EP 810 / SW 46-3.1-G 256		
SW 50	-3.1-	53.3	58.0	M 33	1.1/4"	SW 50-1-G 51	SW 36-1-G 43	90.0	EP 810 / SW 50-3.1-G 90		
SW 50	-3.1-	53.3	58.0	M 33	1.1/4"	SW 50-1-G 51	SW 36-2-G 120	163.0	EP 810 / SW 50-3.1-G 163		
SW 50	-3.1-	120.5	122.5	M 33	1.1/4"	SW 50-1-G 81	SW 36-1-G 43	116.0	EP 810 / SW 50-3.1-G 116		
SW 50	-3.1-	79.2	87.0	M 33	1.1/4"	SW 50-1-G 81	SW 36-2-G 120	189.0	EP 810 / SW 50-3.1-G 189		

Type -3.1-
Adjustable Telescopic
Corrosion Cap
for bolted joints
without washers

Material :
LD-PE,
low density polyethylene

Standard Colour :
black

Individual Productions :
On request we develop and produce
individually tailored solutions next
to the standard items of this range:
additional dimensions, different
materials and new colours

We would be pleased to advise you.

 sealwell

Should your requirements not be shown please ask for a separate quotation.
SEALWELL products and specifications are subject to improvement and change without notice.

Bolt and Nut Adjustable Telescopic Corrosion Cap

For bolted joints **without** washers
 With anti-vibration locking lip
 Adjustable for extremely large bolt length

EX STOCK
 400m
 Parts
DELIVERY SERVICE

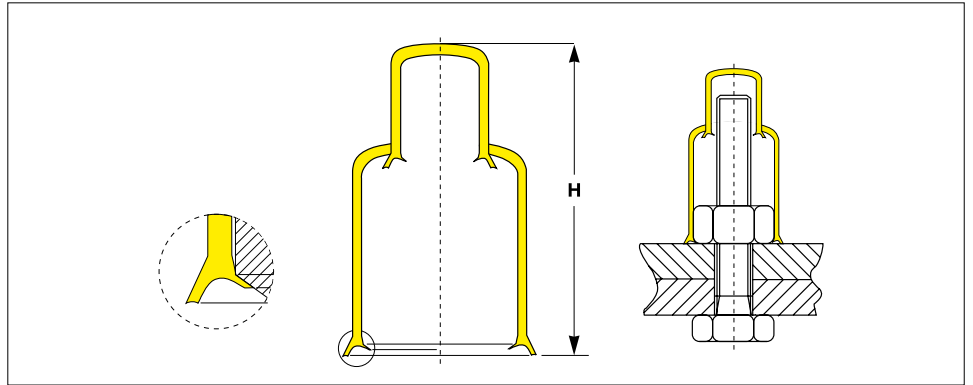

All dimensions in mm

Type -3.1-
 Adjustable Telescopic
 Corrosion Cap for bolted joints
 without washers

Material :
 LD-PE,
 low density polyethylene

Standard Colour :
 black

- Resistant against chemicals
- Temperature range,
 resistant from -25°C up to +70°C

Type 3.1
 For bolted joints without washers
 With anti-vibration locking lip
 Adjustable for extremely large bolt
 length



		Base cap					Top Cap		Telescopic Corrosion Cap	
Widths across Flats	Type	Dimensions of caps		Thread			Reference- No. EP 810/	Max. Height inside H	EP 810 Type -3.1-	
		Height inside h ₁	Height outside H	Metric Thread	DIN 11 - UNC American National Standards	Reference- No. EP 810/			Reference- No.	
SW 55	-3.1-	56.8	60.0	M 36	1.3/8"	SW 55-1-G 55	SW 36-1-G 43	93.0	EP 810 / SW 55-3.1-G 93	
SW 55	-3.1-	56.8	60.0	M 36	1.3/8"	SW 55-1-G 55	SW 36-2-G 120	166.0	EP 810 / SW 55-3.1-G 166	
SW 55	-3.1-	161.4	165.0	M 36	1.3/8"	SW 55-1-G 155	SW 36-1-G 43	198.0	EP 810 / SW 55-3.1-G 198	
SW 55	-3.1-	273.0	276.0	M 36	1.3/8"	SW 55-1-G 155	SW 36-2-G 120	271.0	EP 810 / SW 55-3.1-G 271	
SW 60	-3.1-	57.1	61.0	M 39	1.1/2"	SW 60-1-G 57	SW 41-1-G 46	102.0	EP 810 / SW 60-3.1-G 102	
SW 60	-3.1-	57.1	61.0	M 39	1.1/2"	SW 60-1-G 57	SW 41-2-G 76	125.0	EP 810 / SW 60-3.1-G 125	
SW 60	-3.1-	109.4	113.0	M 39	1.1/2"	SW 60-1-G 107	SW 41-1-G 46	154.0	EP 810 / SW 60-3.1-G 154	
SW 60	-3.1-	109.4	113.0	M 39	1.1/2"	SW 60-1-G 107	SW 41-2-G 76	178.0	EP 810 / SW 60-3.1-G 178	
SW 65	-3.1-	57.2	64.0	M 42	1.5/8"	SW 65-1-G 61	SW 41-1-G 46	102.0	EP 810 / SW 65-3.1-G 102	
SW 65	-3.1-	57.2	64.0	M 42	1.5/8"	SW 65-1-G 61	SW 41-1-G 76	126.0	EP 810 / SW 65-3.1-G 126	
SW 65	-3.1-	123.0	126.0	M 42	1.5/8"	SW 65-1-G 123	SW 41-1-G 46	168.0	EP 810 / SW 65-3.1-G 168	
SW 65	-3.1-	123.0	126.0	M 42	1.5/8"	SW 65-1-G 123	SW 41-1-G 76	191.0	EP 810 / SW 65-3.1-G 191	
SW 70	-3.1-	65.0	62.0	M 45	1.3/4"	SW 70-1-G 63	SW 46-1-G 49	107.0	EP 810 / SW 70-3.1-G 107	
SW 70	-3.1-	65.0	62.0	M 45	1.3/4"	SW 70-1-G 63	SW 46-1-G 144	202.0	EP 810 / SW 70-3.1-G 202	
SW 70	-3.1-	113.5	118.0	M 45	1.3/4"	SW 70-1-G 113	SW 46-1-G 49	159.0	EP 810 / SW 70-3.1-G 159	
SW 70	-3.1-	113.5	118.0	M 45	1.3/4"	SW 70-1-G 113	SW 46-1-G 144	254.0	EP 810 / SW 70-3.1-G 254	
SW 75	-3.1-	113.0	114.5	M 48	1.7/8"	SW 75-1-G 66	SW 46-1-G 49	108.0	EP 810 / SW 75-3.1-G 108	
SW 75	-3.1-	208.0	210.0	M 48	1.7/8"	SW 75-1-G 66	SW 46-1-G 144	203.0	EP 810 / SW 75-3.1-G 203	
SW 75	-3.1-	92.8	97.0	M 48	1.7/8"	SW 75-1-G 96	SW 46-1-G 49	138.0	EP 810 / SW 75-3.1-G 138	
SW 75	-3.1-	235.5	239.0	M 48	1.7/8"	SW 75-1-G 96	SW 46-1-G 144	233.0	EP 810 / SW 75-3.1-G 233	
SW 80	-3.1-	71.0	77.0	M 52		SW 80-1-G 70	SW 50-1-G 51	119.0	EP 810 / SW 80-3.1-G 119	
SW 80	-3.1-	71.0	77.0	M 52		SW 80-1-G 70	SW 50-1-G 81	145.0	EP 810 / SW 80-3.1-G 145	
SW 80	-3.1-	179.6	182.0	M 52		SW 80-1-G 130	SW 50-1-G 51	178.0	EP 810 / SW 80-3.1-G 178	
SW 80	-3.1-	130.0	133.0	M 52		SW 80-1-G 130	SW 50-1-G 81	204.0	EP 810 / SW 80-3.1-G 204	

Should your requirements not be shown please ask for a separate quotation.
 SEALWELL products and specifications are subject to improvement and change without notice.

Bolt and Nut Adjustable Telescopic Corrosion Cap

For bolted joints without washers

With anti-vibration locking lip

Adjustable for extremely large bolt length



CAPTOP®

All dimensions in mm

		Base cap					Top Cap		Telescopic Corrosion Cap		
Widths across Flats	Type	Dimensions of caps		Thread			Reference-No. EP 810/	Max. Height inside H	EP 810 Type -3.1-		
		Height Inside h _r	Height outside H	Metric Thread	DIN 11 - UNC American National Standards	Reference-No. EP 810/			Reference-No.		
SW 85	-3.1-	71.3	75.0	M 56		SW 85-1-G 74	SW 55-1-G 55	123.0	EP 810 / SW	85-3.1-G 123	
SW 85	-3.1-	71.3	75.0	M 56		SW 85-1-G 74	SW 55-1-G 155	227.0	EP 810 / SW	85-3.1-G 227	
SW 85	-3.1-	133.6	138.0	M 56		SW 85-1-G 134	SW 55-1-G 55	185.0	EP 810 / SW	85-3.1-G 185	
SW 85	-3.1-	133.6	138.0	M 56		SW 85-1-G 134	SW 55-1-G 155	290.0	EP 810 / SW	85-3.1-G 290	
SW 90	-3.1-	84.0	88.0	M 60		SW 90-1-G 78	SW 60-1-G 57	136.0	EP 810 / SW	90-3.1-G 136	
SW 90	-3.1-	84.0	88.0	M 60		SW 90-1-G 78	SW 60-1-G 107	188.0	EP 810 / SW	90-3.1-G 188	
SW 90	-3.1-	145.0	145.0	M 60		SW 90-1-G 140	SW 60-1-G 57	192.0	EP 810 / SW	90-3.1-G 192	
SW 90	-3.1-	145.0	145.0	M 60		SW 90-1-G 140	SW 60-1-G 107	244.0	EP 810 / SW	90-3.1-G 244	
SW 95	-3.1-	85.4	90.0	M 64		SW 95-1-G 86	SW 65-1-G 61	137.0	EP 810 / SW	95-3.1-G 137	
SW 95	-3.1-	85.4	90.0	M 64		SW 95-1-G 86	SW 65-1-G 123	203.0	EP 810 / SW	95-3.1-G 203	
SW 95	-3.1-	143.0	148.0	M 64		SW 95-1-G 143	SW 65-1-G 61	195.0	EP 810 / SW	95-3.1-G 195	
SW 95	-3.1-	143.0	148.0	M 64		SW 95-1-G 143	SW 65-1-G 123	261.0	EP 810 / SW	95-3.1-G 261	
SW 100	-3.1-	89.8	94.0	M 68		SW 100-1-G 90	SW 70-1-G 63	146.0	EP 810 / SW	100-3.1-G 146	
SW 100	-3.1-	89.8	94.0	M 68		SW 100-1-G 90	SW 70-1-G 113	198.0	EP 810 / SW	100-3.1-G 198	
SW 100	-3.1-	150.0	156.0	M 68		SW 100-1-G 150	SW 70-1-G 63	207.0	EP 810 / SW	100-3.1-G 207	
SW 100	-3.1-	150.0	156.0	M 68		SW 100-1-G 150	SW 70-1-G 113	258.0	EP 810 / SW	100-3.1-G 258	
SW 105	-3.1-	92.7	98.0	M 72		SW 105-1-G 90	SW 75-1-G 66	150.0	EP 810 / SW	105-3.1-G 150	
SW 105	-3.1-	92.7	98.0	M 72		SW 105-1-G 90	SW 75-1-G 96	180.0	EP 810 / SW	105-3.1-G 180	
SW 105	-3.1-	149.1	154.0	M 72		SW 105-1-G 150	SW 75-1-G 66	207.0	EP 810 / SW	105-3.1-G 207	
SW 105	-3.1-	149.1	154.0	M 72		SW 105-1-G 150	SW 75-1-G 96	236.0	EP 810 / SW	105-3.1-G 236	

Should your requirements not be shown please ask for a separate quotation.

SEALWELL products and specifications are subject to improvement and change without notice.

Type -3.1-
Adjustable Telescopic
Corrosion Cap
for bolted joints
without washers

Material :
LD-PE,
low density polyethylene

Standard Colour :
black

Individual Productions :
On request we develop and produce
individually tailored solutions next
to the standard items of this range:
additional dimensions, different
materials and new colours

We would be pleased to advise you.

 sealwell

Bolt and Nut Adjustable Telescopic Snap Caps

For bolted joints with washers
 With anti-vibration locking lip
 Adjustable for extremely large bolt length

prompt
 MADE-TO-ORDER
 VOLUME

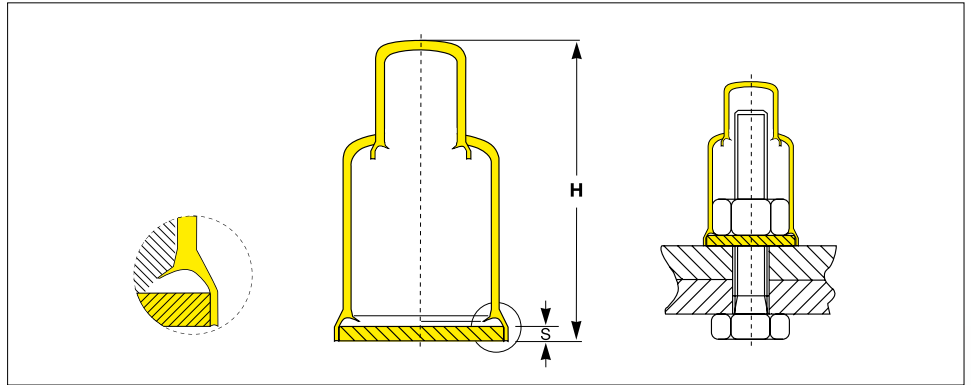

All dimensions in mm

Type -3.2-
 Adjustable Telescopic
 Corrosion Cap for bolted joints
 with washers

Widths across Flats	Base Cap							Top Cap	Telescopic Cap	
	Type	Dimensions of caps			Thread			Reference- No. EP 810/	Max. Height inside H	EP 810 Type -3.2-
		Height inside h ₁	Height outside H	Thickness Washer S	Metric Thread	DIN 11 · UNC American National Standards	Reference- No. EP 810/			Reference-No.
SW 24	-3.2-	67.2	70.0	3.0	M 16	.9/16"	SW 24 -2- G 69	SW 17 -1- G 29	91.0	EP 810 / SW 24 -3.2- G 91
SW 24	-3.2-	67.2	70.0	3.0	M 16	.9/16"	SW 24 -2- G 69	SW 17 -1- G 45	107.0	EP 810 / SW 24 -3.2- G 107
SW 30	-3.2-	82.0	84.0	3.0	M 20		SW 30 -2- G 82	SW 19 -1- G 29	106.0	EP 810 / SW 30 -3.2- G 106
SW 30	-3.2-	82.0	84.0	3.0	M 20		SW 30 -2- G 82	SW 19 -1- G 50	127.0	EP 810 / SW 30 -3.2- G 127
SW 36	-3.2-	120.0	122.5	4.0	M 24	.7/8"	SW 36 -2- G 120	SW 24 -1- G 31	148.0	EP 810 / SW 36 -3.2- G 148
SW 36	-3.2-	120.0	122.5	4.0	M 24	.7/8"	SW 36 -2- G 120	SW 24 -2- G 69	177.0	EP 810 / SW 36 -3.2- G 177
SW 41	-3.2-	88.0	92.0	4.0	M 27	1."	SW 41 -2- G 80	SW 30 -1- G 34	116.0	EP 810 / SW 41 -3.2- G 116
SW 41	-3.2-	88.0	92.0	4.0	M 27	1."	SW 41 -2- G 80	SW 30 -1- G 120	199.0	EP 810 / SW 41 -3.2- G 199
SW 46	-3.2-	81.7	114.3	4.0	M 30	1.1/8"	SW 46 -2- G 83	SW 30 -1- G 34	110.0	EP 810 / SW 46 -3.2- G 110
SW 46	-3.2-	194.3	196.7	4.0	M 30	1.1/8"	SW 46 -2- G 83	SW 30 -1- G 120	192.0	EP 810 / SW 46 -3.2- G 192
SW 50	-3.2-	87.0	90.0	5.0	M 33	1.1/4"	SW 50 -2- G 86	SW 36 -1- G 43	123.0	EP 810 / SW 50 -3.2- G 123
SW 50	-3.2-	199.0	201.0	5.7	M 33	1.1/4"	SW 50 -2- G 86	SW 36 -2- G 120	197.0	EP 810 / SW 50 -3.2- G 197
SW 55	-3.2-	89.0	92.0	5.0	M 36	1.3/8"	SW 55 -2- G 90	SW 36 -1- G 43	125.0	EP 810 / SW 55 -3.2- G 125
SW 55	-3.2-	89.0	92.0	5.0	M 36	1.3/8"	SW 55 -2- G 90	SW 36 -2- G 120	199.0	EP 810 / SW 55 -3.2- G 199
SW 55	-3.2-	163.0	173.0	5.0	M 36	1.3/8"	SW 55 -2- G 160	SW 36 -1- G 43	199.0	EP 810 / SW 55 -3.2- G 199
SW 55	-3.2-	152.0	154.0	7.5	M 36	1.3/8"	SW 55 -2- G 160	SW 36 -2- G 120	273.0	EP 810 / SW 55 -3.2- G 273
SW 60	-3.2-	106.0	106.0	6.0	M 39	1.1/2"	SW 60 -2- G 93	SW 41 -1- G 46	146.0	EP 810 / SW 60 -3.2- G 146
SW 60	-3.2-	101.4	106.0	6.0	M 39	1.1/2"	SW 60 -2- G 93	SW 41 -1- G 76	170.0	EP 810 / SW 60 -3.2- G 170

Material :
 LD-PE,
 low density polyethylene

Standard Colour :
 black

- Resistant against chemicals
- Broad Temperature range,
 resistant from -25°C up to +70°C

Type 3.2
 For bolted joints with washers
 With anti-vibration locking lip
 Adjustable for extremely large bolt
 length

Should your requirements not be shown please ask for a separate quotation.
 SEALWELL products and specifications are subject to improvement and change without notice.

Bolt and Nut Adjustable Telescopic Snap Caps

For bolted joints with washers

With anti-vibration locking lip

Adjustable for extremely large bolt length



CAPTOP®

All dimensions in mm

Widths across Flats	Type	Base Cap					Thread	Top Cap		Telescopic Cap		
		Dimensions of caps			Metric Thread	DIN 11 · UNC American National Standards		Reference- No. EP 810/	Reference- No. EP 810/	Max. Height inside H	EP 810 Type -3.2-	
		Height Inside	Height outside	Thickness Washer							Reference- No. EP 810/	Reference- No.
SW 65	-3.2-	95.2	98.0	7.7	M 42	1.5/8"	SW 65 -2- G 98	SW 41 -1- G 46	141.0	EP 810 / SW 65 -3.2- G 141		
SW 65	-3.2-	166.2	168.2	7.7	M 42	1.5/8"	SW 65 -2- G 98	SW 41 -1- G 76	164.0	EP 810 / SW 65 -3.2- G 164		
SW 70	-3.2-	100.0	102.0	7.0	M 45	1.3/4"	SW 70 -2- G 100	SW 46 -1- G 49	145.0	EP 810 / SW 70 -3.2- G 145		
SW 70	-3.2-	100.0	102.0	7.0	M 45	1.3/4"	SW 70 -2- G 100	SW 46 -1- G 144	240.0	EP 810 / SW 70 -3.2- G 240		
SW 80	-3.2-	136.0	141.0	8.0	M 52		SW 80 -2- G 139	SW 50 -1- G 51	184.0	EP 810 / SW 80 -3.2- G 184		
SW 75	-3.2-	103.4	110.0	8.0	M 48	1.7/8"	SW 75 -2- G 103	SW 46 -1- G 144	243.0	EP 810 / SW 75 -3.2- G 243		
SW 75	-3.2-	103.4	110.0	8.0	M 48	1.7/8"	SW 75 -2- G 103	SW 46 -1- G 49	149.0	EP 810 / SW 75 -3.2- G 149		
SW 80	-3.2-	136.0	141.0	8.0	M 52		SW 80 -2- G 139	SW 50 -1- G 81	210.0	EP 810 / SW 80 -3.2- G 210		
SW 85	-3.2-	83.0	86.0	9.0	M 56		SW 85 -2- G 83	SW 55 -1- G 55	134.0	EP 810 / SW 85 -3.2- G 134		
SW 85	-3.2-	83.0	86.0	9.0	M 56		SW 85 -2- G 83	SW 55 -1- G 155	239.0	EP 810 / SW 85 -3.2- G 239		
SW 90	-3.2-	81.0	85.3	9.2	M 60		SW 90 -2- G 83	SW 60 -1- G 57	133.0	EP 810 / SW 90 -3.2- G 133		
SW 90	-3.2-	81.0	85.3	9.2	M 60		SW 90 -2- G 83	SW 60 -1- G 107	185.0	EP 810 / SW 90 -3.2- G 185		
SW 95	-3.2-	140.0	145.0	9.0	M 64		SW 95 -2- G 140	SW 65 -1- G 61	192.0	EP 810 / SW 95 -3.2- G 192		
SW 95	-3.2-	140.0	145.0	9.0	M 64		SW 95 -2- G 140	SW 65 -1- G 123	258.0	EP 810 / SW 95 -3.2- G 258		
SW 100	-3.2-	150.0	158.0	9.0	M 68		SW 100 -2- G 150	SW 70 -1- G 63	207.0	EP 810 / SW 100 -3.2- G 207		
SW 100	-3.2-	150.0	158.0	9.0	M 68		SW 100 -2- G 150	SW 70 -1- G 113	258.0	EP 810 / SW 100 -3.2- G 258		
SW 105	-3.2-	159.0	164.0	9.0	M 72		SW 105 -2- G 160	SW 75 -1- G 66	217.0	EP 810 / SW 105 -3.2- G 217		
SW 105	-3.2-	159.0	164.0	9.0	M 72		SW 105 -2- G 160	SW 75 -1- G 96	246.0	EP 810 / SW 105 -3.2- G 246		

Should your requirements not be shown please ask for a separate quotation.

SEALWELL products and specifications are subject to improvement and change without notice.

Type -3.2-
Adjustable Telescopic
Corrosion Cap
for bolted joints
with washers

Material :
LD-PE,
low density polyethylene

Standard Colour :
black

Individual Productions :
On request we develop and produce
individually tailored solutions next
to the standard items of this range:
additional dimensions, different
materials and new colours

We would be pleased to advise you.

 sealwell